

COVER PAGE

Research Paper Title: **“Learner Support Services in Open Distance Learning System:
Plug and Play Model of Education”**

Name of the author: **Dr. Narendra Mishra**

Designation: **Assistant Professor, IMTCDL**

Official contact address: **IMTCDL, Ghaziabad.**

Phone Numbers: Mobile: **09312208371**

Landline:

E Mail ID: **nmmishra@imtcdl.ac.in**, nmmishra@hotmail.com

DECLARATION

I, the undersigned, hereby would like to explicitly state that the write-up titled, "**Learner Support Services in Open Distance Learning System: Plug and Play Model of Education**" is original and has not been published earlier, or that it is not under consideration for

Possible publication elsewhere.

Name : Dr. Narendra Mishra

Signature :

A handwritten signature in black ink that reads "nm mishra". The signature is written in a cursive style and is positioned above a horizontal line that spans the width of the signature area.

Date : 13/01/2021

Learner Support Services in Open Distance Learning System: Plug and Play Model of Education

Dr. Narendra Mishra

Associate Professor, IMTCDL, Ghaziabad, India.

Email: nmmishra@imtc dl.ac.in, nmmishra@hotmail.com Mobile No.: 09312208371

Abstract

The core component of the institute of open and distance learning system is learner support services. The academic as well as academic support services are included in this system. The learner support services are the processes, which support the learner in their path of learning. This includes initiation, selection of important activities, planning, monitoring, execution and closure. This is a project life cycle model and is followed to ensure the Define, Measure, Analyse, Improve and Control (DMAIC) for process improvement. Learner support system is driven by the DMAIC model of life cycle. The purpose of this paper is to design and integrate the learner support services model for Open and Distance Learning Institute based on

the descriptive study and the researcher's decade long experience in open and distance learning. It provides interactive support services with least manual intervention, staff responsibility for providing the services, ICT, method of service delivery and execution mechanism to ensure effective and efficient student support services.

Keywords: Support Services, Open Distance Learning (ODL), Integrate, System Design, Dashboard.

Introduction

Support Services: Support services is one of the main components of any ODL Institution. The support service

helps the learner in the learning path and gives support in the various activities of learning as providing study materials, print as well as electronic form, ensure the access of library services, counselling support online and offline both and proper conduct of assignment and examination. The learner support services can be classified based on the requirement of learners. The need of support services is emerged in the ODL system based on the survey as the learner faced the following difficulties: Less interaction with counsellors who can facilitate learning, unnecessary intervention and domination by the support staff, least access to information, fund constraints, lack of appropriate environment for study, time constraint due to family or work obligations, delay in receiving study material, non-responsiveness and ineffective management services, lack of rapport due to geographical remoteness, lack of self-study skills. The above factors are very common; therefore, the ODL needs a support service model to ensure effective services to the learners.

Requirement for Student Support Service

According to Alan Tait of the Open University UK, who narrated in detail about the learner support services, “the systems have to be developed which do not hamper the institutional needs by paperwork, meetings and other such activities.” In ODL Institution, maximum time the learners are untouched with the process and the instructor. The support service system is one of the major gateway to provide the access and support to the learner. Today, learners are living the smart age where quick and instant support is the need of the user. The support service system is the design of the ODL system, which will help in ensuring a high level of satisfaction among the users.

Non-teaching support mainly move around the day-to-day problem solving related to the confusion of the learner about the program and the activities of general nature, suggestions, feedback, and helping in routing the learner at the right place. The delay and no response create the confusion in the mindset of the learner. Therefore, to ensure the

learner a ready support, it could be provided in the following manners:

Information related support: The non-teaching staff of the ODL institution should provide the basic information regularly to the learner such as the time line, the window of counselling session, the examination process, the credit structure, courses in each program and its relevancy, dead line of the course completion, and regularly connect and ask any difficulty in the process of learning. The ODL institution must assign a group of learner to each non-teaching staff so that an effective way of information sharing is ensured.

Second type of support is institutional related support. Here, the learner is required to understand the ODL institution including its background, the program detail and support services detail. These details must be provided in a very accurate manner so that the learner joins the program.

One of the most important components of the model is the support system, which allows everyone to contact and

access the limited learning without any cost, but during the process of learning the learner engages with counsellor and joins the program. Therefore, this model is based on DMAIC. The learner first tests the quality of the course and then takes a decision to join. Therefore, ODL requires the learner support services.

Learning Support Centre is one of the major requirements to ensure a proper development and guidance of the learner at the local level in any ODL institution. The ODL institution must setup the learner support service centre at different geographical locations so that the learner could be able to interact and get support pertaining to day-to-day problems related to academic counselling, examination, assignment, fee and other general problems.

Framework:

To ensure an effective and efficient Open and Distance Learning Support System, a detailed framework is proposed as:

In step 1, functional requirement of the ODL system is presented in Fig. 1 as:

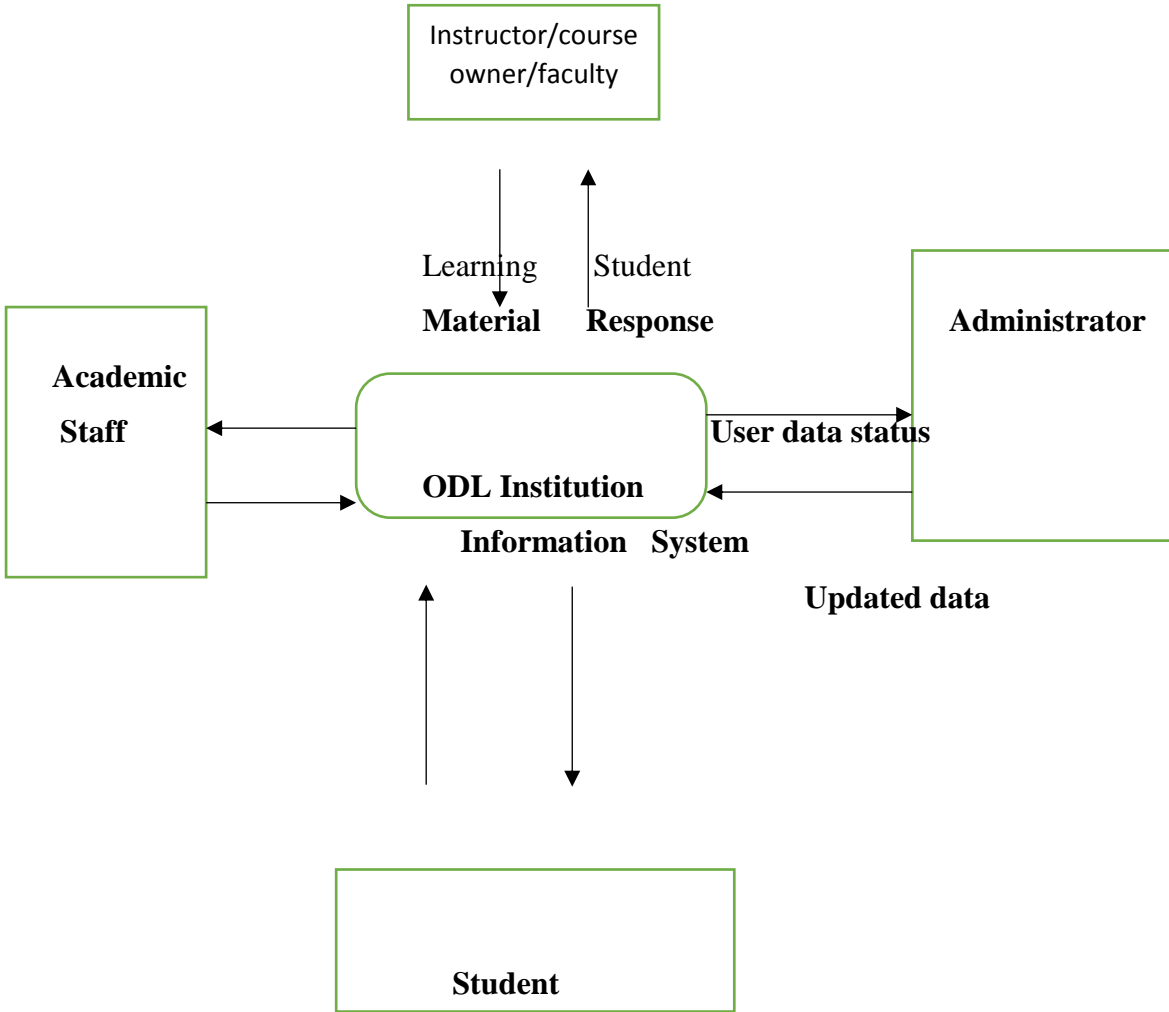

Fig. 1 Functional requirement of the system

Proposed Decomposition Diagram for ODL Institution (Fig. 2):

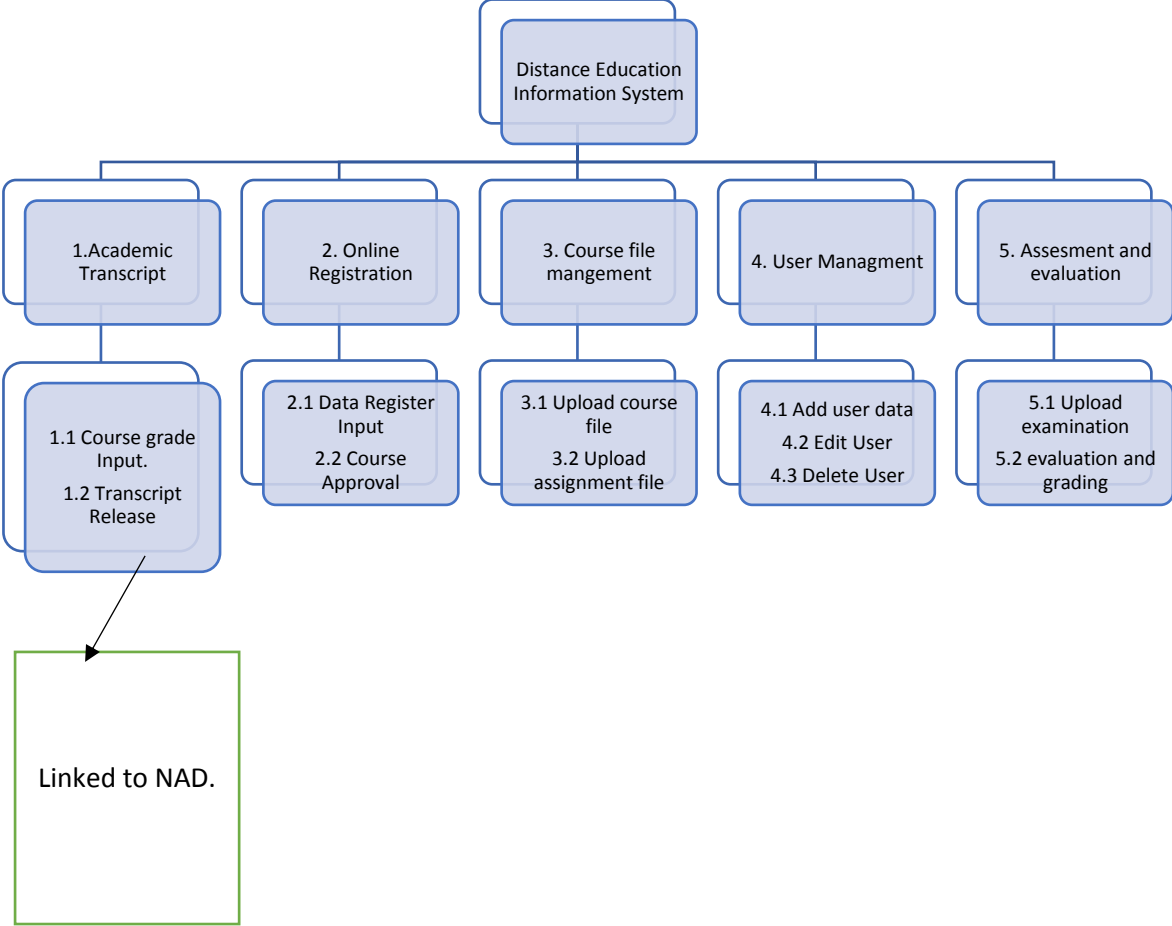
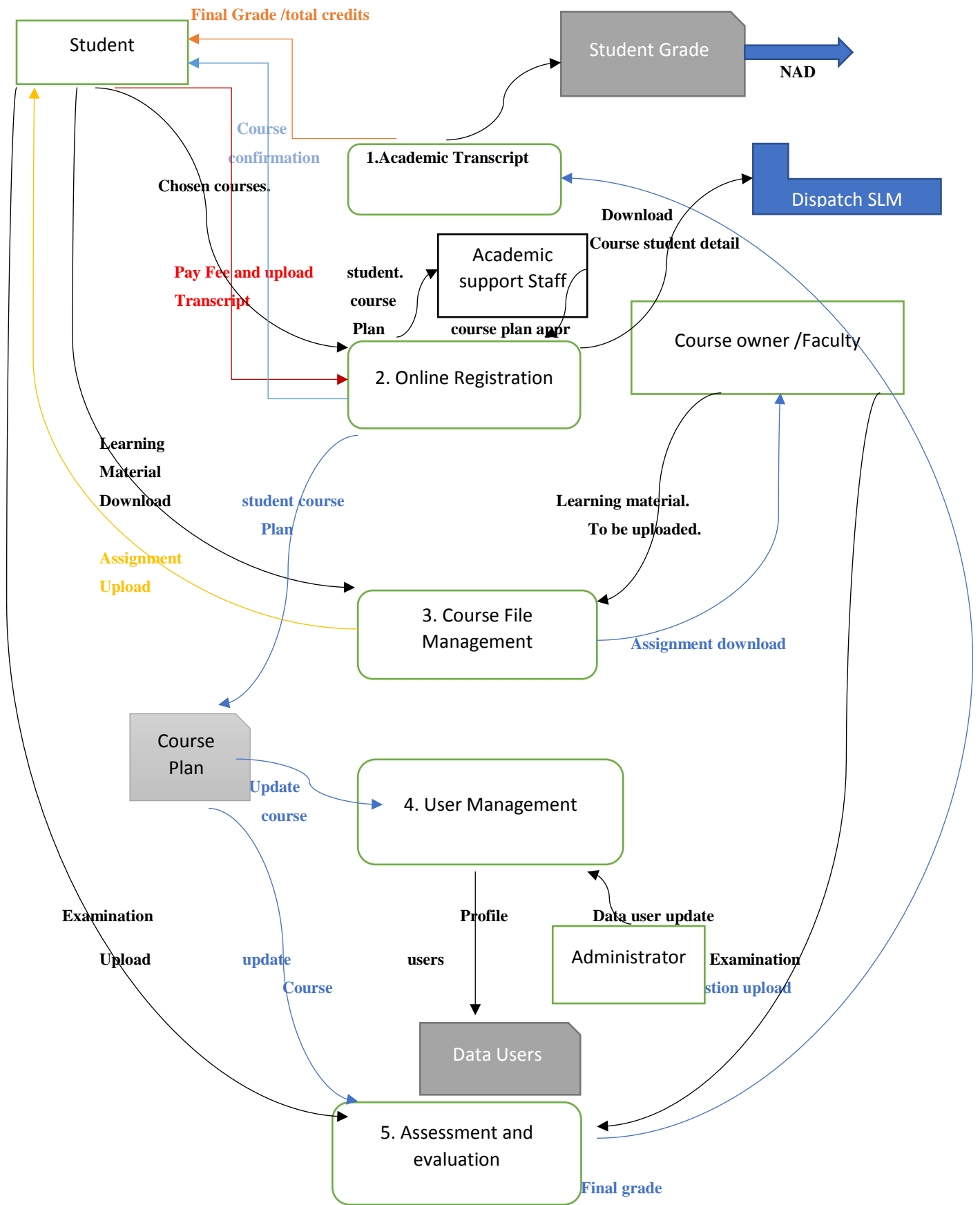

Fig. 2 Proposed decomposition diagram for ODL institution

Data Flow Diagram Level-1 (for ODL Institution)



User related details:

A) **Student:** must have an account that they have to apply to administrator, any individual can sign in and open the account on portal after Aadhaar/passport verification. For international student passport verification is mandatory. Sign up process must be automatic without manual intervention.

The roll number will be issued along with course confirmation.

B) **Course owner / Faculty/ Instructor:** can upload course file, assignment sheet, answer sheet regularly.

C) **Academic staff (counsellor):** must be the authority to approve student academic plan, submit news, and student grade, ensure proper dispatch of study material online and offline.

D) **Administrator:** must be authority to maintain user's sign-up administration.

E) **Head of the Institute:** to have a dashboard with all the 5 modules auto progress check support with visual graph.

F) **Head of Finance:** must be assignment the payment component downloads and

visual dashboard from online registration module.

System Design:

Proposed system is a web based automatic (AI and machine learning driven) integrated Information System that uses 2 tier architecture.

Level 1: handle http requests and give the response after the request is processed by the web server and module program (the program is based on the SOP defined by the institute).

Level 2: handle database directory, mail server, and SNMP (Simple Network management Protocol).

Development tools are freeware and open source which are to be used to implement the system. Depending upon the requirement and use, the developer can choose any open-source ware (For example: PHP/Python as programming language, MySQL/Amazon Aurora/MS SQL Server as database server, and Apache HTTP as web server).

System Architecture:

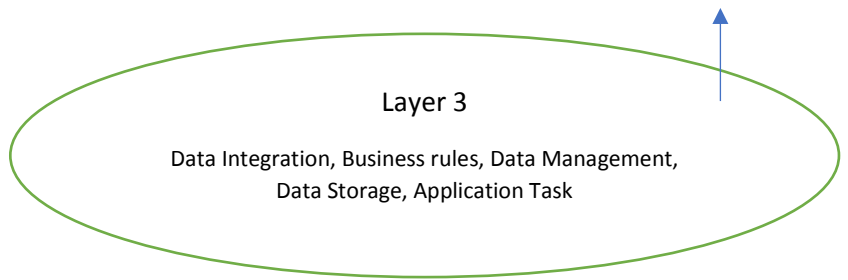
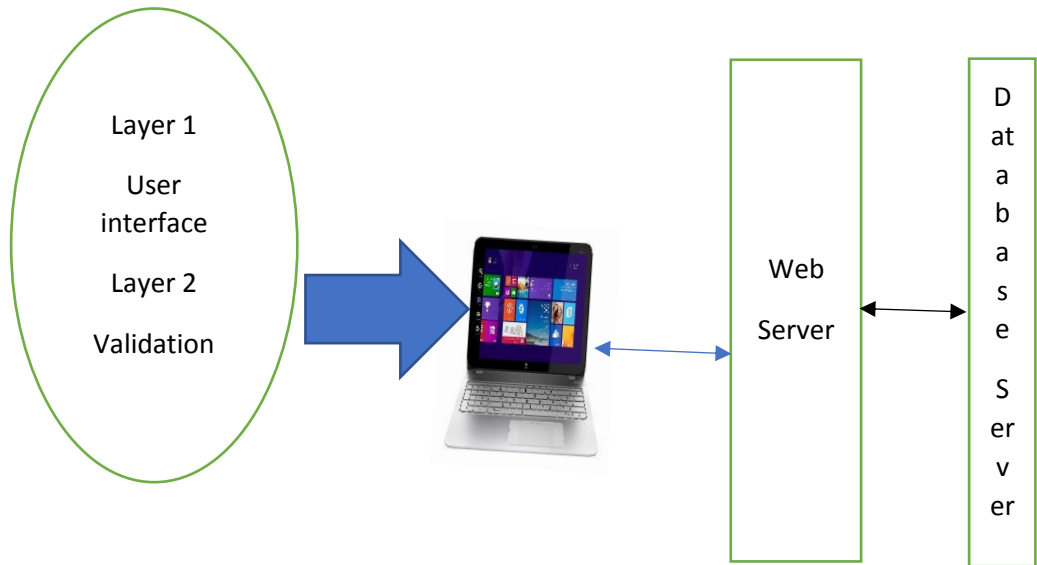

A dashboard view for the student:

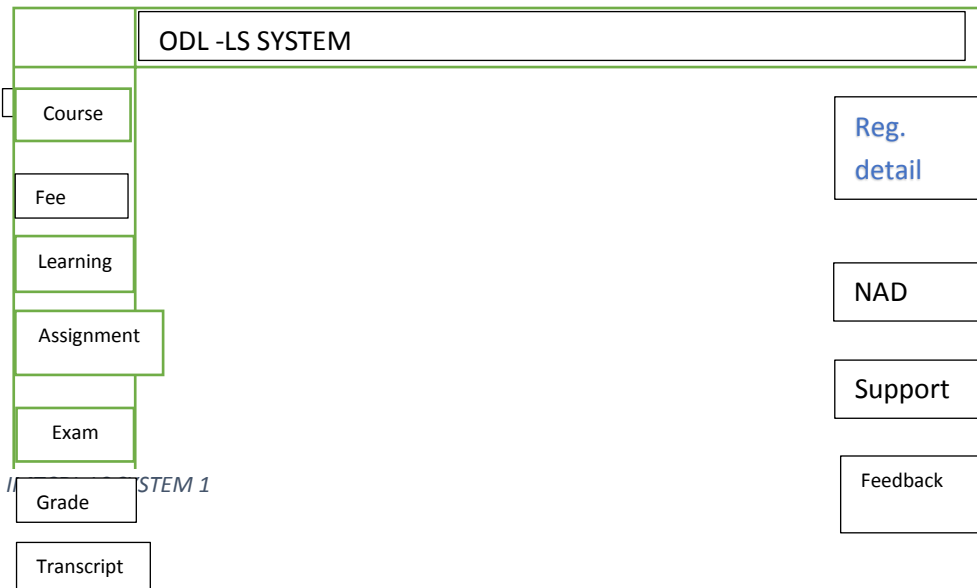

A dashboard View for the Head of the Institute:

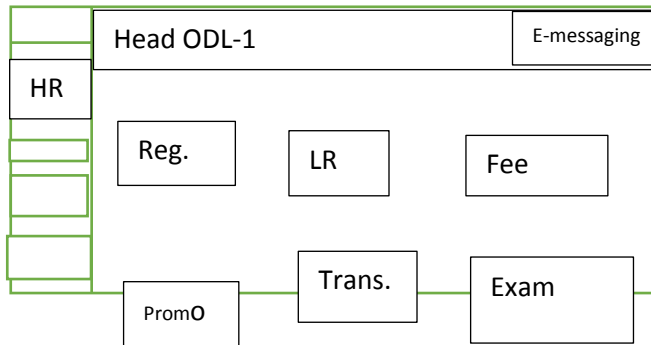

Reg.: LIVE: Student registration detail in the graphical and tabular both auto instant updated

LR: Live: Learning resources related visualization

Fee: Pay Fee related visualization

PromO: Online marketing related live visualization synced with Google AdSense and Google Analytics if any

Trans.: Academic transcript data fixed.

Exam: Live Examination activity visualization

E- messaging: audio, video, text broadcast to all or few directly to users

Note: HR and other parts must be customized in the dashboard as shown in the left most corner.

In the same line, other users such as coordinators', course owners', and counsellors' customized dashboards must be created.

Network of Support Services:

There must be the support systems with three models. The two models depend on the print media and electronically developed content where the printed/E materials are sent to the learners. They send back the E-assignment responses to the learner support centres for evaluation on the respective instructor portal. In the second model, there is additional compulsory seminars and workshop related activities. The third category is where the learner has the option to pick the type of learning as offline (where learner will attain the physical instructor driven counselling at the learner support centre) or online (the learner could attain through synchronous learning platform). The above-discussed Network support services would ensure high level of

integrated learner support, and the ODL institution would be able to provide quality education.

Open and distance learning institute must have a division with the name of student registration and support division for ensuring support to the learner. The division have to setup the learner support centre for giving the support to the learner at the local level in the process of academic support, examination, digital learning support and knowledge development support, etc.

Types of Support Services:

The quality of the study materials and academic support services are the important components of the support services of the ODL institutions. This requires high-speed internet network between the headquarters, LSCs and students. This facility provides the better and improved method of Information sharing.

The setting up of learner support centres, admission, print material as well as electronics material development and dispatch, examination and testing are the main components of the support services. The activities of the support services are:

4.1 Learner support centre establishment:

Locations should be identified keeping in view the need and geography of the region. The centres must be in such a manner so that they can serve the need of the learner and attract the learner toward learning. ITC facilities must be ensured, and high-speed internet connection must be there at the centre.

4.2 Pre-Enrolment Services:

The admission form and prospectus and online/offline admissions with detail collection of fees, documents and providing the services related to support in admission is a part of this process.

4.3 Information services:

The main activity of this process is to provide information about the ODL programme as well as the counselling schedule and to encourage the learners to join the courses as per their suitability.

4.4. Post-enrolment services:

This activity includes self-learning material dispatch,

examination services, digital information service, financial assistance services, information and digital library, IT services, electronic and multimedia services and additional support service.

4.5. Dispatch of self-learning material services:

This activity includes dispatch of study materials, providing examination services, and assignment to a new student and existing students, as well as proper stock keeping, timely processing of the admission and dispatch of the SLM. The production, procurement and distribution are also a part of this process.

4.6. Examination services:

Developing the guidelines for conducting examination and evaluation of assignments; selection of examination centres; appointment of question paper setters, observers, centre superintendent; mark sheet and certificate development and dispatch; developing the new methods of evaluation and assignments are the roles of this process.

4.7 Information and digital library services:

Providing the latest eBook, eSLM, user guidance, case study services, online database, current awareness support and other related information support are the roles of this process.

4.8 Financial assistance support:

The objective of this process is to ensure the financial support to the learner.

4.9 ITC services:

To setup and maintain computer lab and ensure a proper support of the IT related process and make it user friendly are the roles of this process.

4.10 Electronic and multimedia services:

The objective of this process is to ensure a proper development creation and uploading of electronic material and audio-visual material for the learner through extra net platform, also to organize live online seminar of the latest development of the related courses.

4.11 Additional support services:

The objective of this service is to provide the change medium service, transcript service, elective selection service, and helping the

learner in selection of elective as per their requirement and skill, address change support service, provisional certificate, course completion and other services of miscellaneous nature. Issue of enrolment cards services is the part of this process. The additional support service must issue the identity card where the objective and the purpose of the card are to permit the learner to avail the facilities provided by the institute, to allow entry for examination and other purposes is the arrangement of OLS (open learning session).

Conclusion:

The efficiency of the support system depends upon ensuring the plug and play model of education which should be automated and the learning content should be demand driven and free from time and days. The institute should develop the e-content library from the previously recorded lectures and supply them as per the demand. We must ensure 24 x 7 learning and open

learning as well as promotive learning with zero defect, and with this objective the proposed learner support model can be achieved. The most important feature of this model is that any person without paying any fee can join ODL institute and start limited learning but, once he/she opts for a course and registers, a formal way of course with credit will start. This model will help in fulfilling the 'Education 2030 Agenda' with a global commitment of providing education to all and free of cost. This will help in promoting and marketing of the course by engaging the user and developing the test of learning and finally indirectly convincing the user to join the course.

References:

- 1) Tait, A. (2000). Planning student support for open and distance learning. *Open Learning: The Journal of Open, Distance and e-Learning*, 15(3), 287–299.